



EMERGENCY VEHICLES



Demand Quality...You Deserve It!



At Acres, we shall relentlessly seek to better our product, and currently manufacture one of the finest apparatus in this industry. Take note of the fit-and-finish on the exterior and the under-side where it is not noticeable but very much still relevant. The level of workmanship is the same, regardless of whether you may not see it.

Always remember that the level of quality on the exterior of an apparatus (what you can see but may not affect performance) is going to be the same behind panels (where you cannot see but may affect performance). Come and see for yourself the manufacturing process and you'll become a believer!





Highside/Highside aluminum fire rescue bodies with full-depth compartments.

Ergonomically placed controls with excellent service access to key components.



Aluminum tubular sub-frame offers reduced weight, enhanced resistance to corrosion & exceptional strength.

LED interior lighting with automatic door actuated lower intensity & switched higher intensity lighting.

Heating & air-conditioning provides for a balanced climate for the pump operator and crew.

Beautifully upholstered interior provides insulation & noise absorption.



Custom extruded aluminum profiles offer the highest-strength fire-rescue bodies in the industry—also the most appealing.

Highside/Mediumside aluminum fire rescue bodies with full-depth compartments.



Extended front bumper allows for mounting of remote monitor, trash line or winch.

Shore-line auto-eject automatically ejects 12V AC power cord when starter is engaged. Provides power to battery conditioner and 12V air pump to maintain air-brake system pressure in fire hall.

Aluminum roll-up doors with lifetime warranty on the spring-loaded roller system. Dual full-door-height led strip lighting lights up the compartment interior.

18" led ground lighting at all stepping areas illuminates the ground so firefighters can see where they are walking.





Highside/Mediumside aluminum fire rescue body.

Heavy-duty aluminum bumper with NFPA compliant checker-plate for enhanced slip resistance.



Precisely fitted heat-pans protect your pump from freezing—take a peek underneath and see for yourself the precision craftsmanship even where its not noticeable.

Take pride in your apparatus with functional & appealing cab entry steps.

Color-coded rocker switches—red for master warning—yellow for pumphouse heat—blue for fire pump makes for easy operation.

Stainless steel removable wheelwell panels—no rust, ever!

Anodized aluminum rub-rails protect the body from abrasions.

Custom aluminum consoles with stainless steel covers & arborite to prevent surface wear.



Highside/Lowside aluminum fire rescue body.



Shuttle your water requirements with high-horsepower apparatus equipped with large-gallonage poly water tanks. Poly water tanks sold with life-time warranties. Request a dump valve at the back end of the tank to drop loads in minutes. Chutes provide the ability to dump over a 180 degree arc. Enclosed compartments are available to carry porta-tanks, suction hose & aluminum ladders.





Its all starts with a design team that boasts a combination of 70 years of knowledge with one goal in mind.....perfection! Then on to the production line where a precision waterjet shapes aluminum sheets which are then formed to high part tolerances. Journeymen & CWB certified alumi-

num welders assemble & weld the body components together, leaving very appealing, strong, penetrating welds. Journeymen electrical & plumbing personnel with diversified experience in multiple industries plan, plumb and wire to a level of dependability that will last a life-time.

From light loads to heavy loads, Acres Apparatus comes with the same level of quality, no compromises, ever! Regardless the type of apparatus, the application, whom ever the end user is, rest

assured that your apparatus is built with the same level of pride and quality. Be it city, town, village, rural municipality or first nation..... Same commitment, same excellence!



Many thanks to our customers who have all taken great pride in their apparatus!
The sacrifice you make so willingly and voluntarily every time you respond to those
in need, drives our employees to manufacture you the finest and most reliable
apparatus this country has to offer! And that's not all..... Acres will always strive to
become even better!



At Acres we want your business because you deserve our quality! From sub-frames, to compartmentation, to water distribution, to electrical distribution, to water tank design ,to customer service, we exceed the standard! If we are ever given the chance to show you, you'll see why. Every employee yearns to please you, our customer, and does so with superior craftsmanship.

Improve safety on the road with NFPA compliant red/yellow reflective chevron striping.

Aluminum extruded pumphouse provides a long-lasting corrosion resisting structure. No rust to deal with.

Hose-bed tarps are produced in-house by the same people. Aluminum flat bars are bonded to the tarp cross-wise, then covered with strips of vinyl. These bars provide extra support to keep the tarp from whipping in the wind.



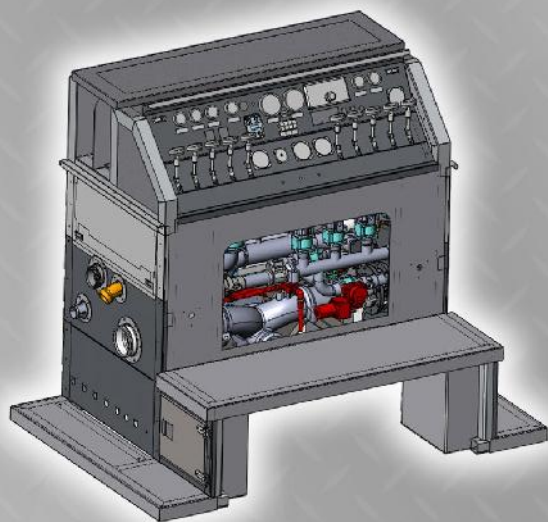

Acres was one of the first OEM's to introduce a rubber-mounted pump frame in addition to a rubber-mounted pump-house further isolating drive-line vibrations. This will result in lowering lifecycle cost related to equipment fatigue.

Our sub-frames have redundant cross-members offering substantial support for poly tanks. Structures are designed to carry body loads with an emphasis on design to reduce stresses imposed on welded joints.

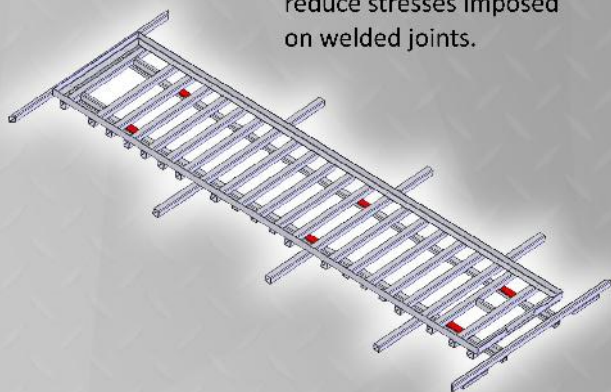

Electrical harnesses are color and number-coded to identify their functions. Wherever possible, connections on the exterior are eliminated to prevent circuit corrosion.

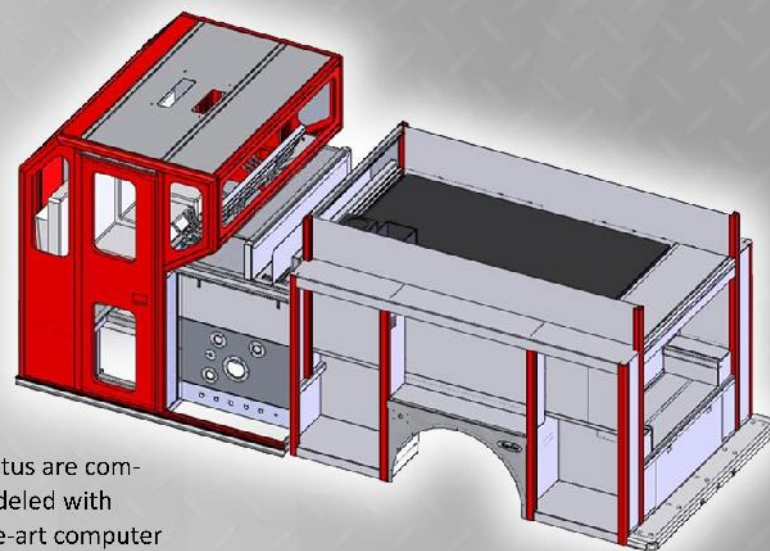

Our apparatus are completely modeled with state-of-the-art computer aided design software, which allow our engineering staff to conceive designs, and approve them before they are placed in production.

All pumper water tanks are produced in-house from poly, baffled to NFPA requirements. Tanks come with life-time warranty by Acres.

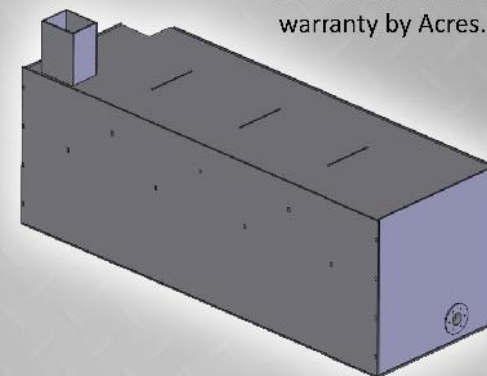



EMERGENCY VEHICLES

Distributed by:



1988 LTD.

369 Archibald St.
Winnipeg, Manitoba
R2J 0W6
carrierefireandsafety.com

Phone: (204) 233-3737
Fax: (204) 237-7675
Toll Free: 1-800-432-5135
email: craig@cfsev.ca



Demand Quality...You Deserve It!

Acres Industries Inc.
Ph: 204-824-2392

200 Green Acres Road
email: info@acresev.ca

Wawanesa, Manitoba R0K 2G0
Fax: 204-824-2761